

LIFAN POWER USA

160F

168F

168F-2

168F-D

168F-2D



ENGINES

PREFACE

Thank you for choosing a general gasoline engine by our company.

Based on the latest engine technology at home and abroad, our Co. has individually developed general gasoline engines with 4-stroke single cylinder, OHV and forced-air cooling. The engine is characterized by advanced design, compact structure, reliable performance, convenient service low fuel consumption and easy speed adjustment. They are widely used as ideal power in many fields such as generating set, tour, open working, public place of entertainment, construction machine, agricultural machinery, etc. the vital part bodies including cylinder cover, crankcase, etc, are all cast formed with aluminum alloy. Laser-scanning technology, 3D shaping technology and CN program processing technology used in the mould production upgrade the engine surface and manufacturing accuracy obviously. Applying auto-press reducing system and centrifugal fly hammer regulating system assure that assemblies equipped with the engine function smoothly and reliably as well as the engine start easily. Besides, the introduction of the lubricant film-sensing protection system prevents accidental damage of the engine for poor lubrication.

The manual gives information with respect with respect to operation and maintenance of the general gasoline engine, and be sure to read it carefully first before operating. All the materials and diagrams of this manual are in accordance with the newest products at the publishing time. Due to revision and other change, the information described in this manual may be a little different from the ac-

tual status. The copyright of this manual belongs to our Co., any group or individual is forbidden to reprint or copy any it. The manual is subject to change without notice.

Please pay special attention to statements preceded by the following words:

⚠ WARNING

● **A warning is used to alert the user to fact that hazardous operation and maintenance procedures may result in injury to or death of personnel if not strictly observed.**

CAUTION

● **A caution is used to alert the user to fact that hazardous operation and maintenance procedures may result in injury to or death of personnel if not strictly observed.**

NOTE

● **A note is used to give helpful information.**

Although the engine conforms to the safety requirement of EN1679-1, the user must notice the possible danger when they install the engine with other terminal products because the different installing purposes maybe will result in new danger to the engine and its driving product. So, all users must be responsible to take action for assuring the safety.

CONTENTS

Safety Precautions	5
Parts Description.....	7
Battery connection.....	8
Control Connection of Remote Distance (option).....	10
Pre-Operating Inspection.....	11
I .Engine oil.....	11
II .Oil in the reduction gear box	12
III.Air cleaner	13
IV.Fuel and fuel tank	15
Starting of the Engine	18
Operation	21
Stop.....	23
Exhaust Control System	24
I Maintenance.....	24
II .Replacement of parts	24
III.Modifying	25
IV.Problems affecting exhaust emissions	25

Maintenance.....	26
I Maintenance schedule.....	26
II .Method.....	28
Transport, Storage and Removal from Storage.....	37
I Transport.....	37
II .Storage	37
IV.Removal from storage.....	39
Troubleshooting	40
I .Starting engine difficultly	40
II .Low gasoline engine power output.....	43
III.Gasoline engine cannot run smoothly	44
IV.Stop suddenly when running	45
V .Gasoline engine is excessively hot	47
VI.There is abnormal noise when engine running	48
Specifications.....	50
I .Main specifications.....	50
II .Timing of distribution.....	51
III.Torque of important bolts	52
Electric Diagram.....	53

SAFETY PERCAUTIONS

⚠ WARNING

● **Before operating the engine, be sure to read and familiar with the manual carefully, otherwise injury to personnel or damage to equipment may occur.**

Please pay special attention to the following:

1. Running the engine in a well-ventilated place, keep it at least one meter away from building walls or other equipments, keep away from inflammables such as gasoline, matches and so on to avoid possibility of fire.
2. Keep the engine out of reach of children and pets to avoid accidents.
3. Operator on the engine has been specially trained.]
4. Refuel in a well-ventilated area with the engine stopped, and in places refueling or storing gasoline, no smoking and any flames or sparks.
5. Refuel the fuel tank not too full so as to avoid fuel's spilling out. If there is spilled fuel around, be sure to clean it thoroughly before starting.
6. Locate the engine on a level-working platform to avoid fuel's spilling out.
7. Mack sure the fuel filler cap is tightened securely.
8. The exhaust muffler is very hot during running the engine even after the engine stops. Never touch it, or you may get burns. Transport or store the engine with it cooling down entirely.

9. This machine should not be used underground or in areas where explosive conditions may be present.
10. It's recommended that the operator wears the protection equipment during operation.

PARTS DESCRIPTION

The main part of engine are located as follow (Fig.1)

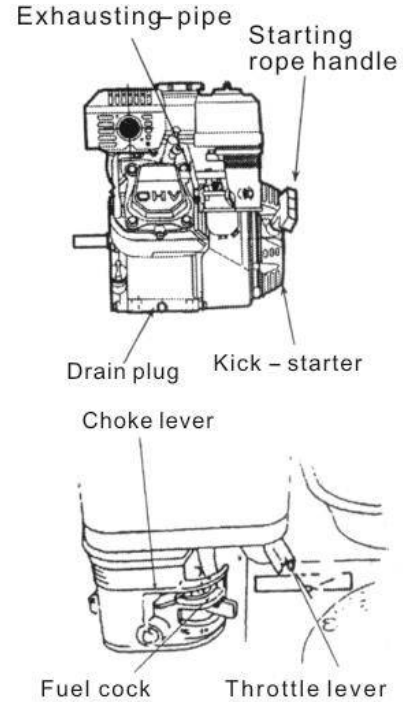
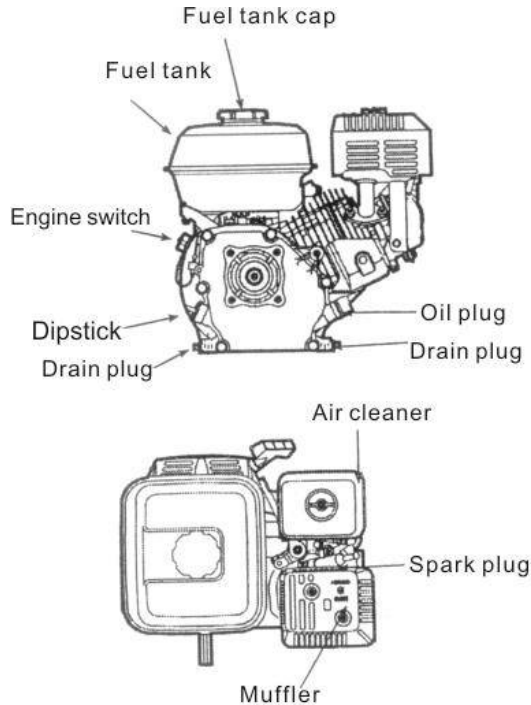

Fig. 1

BATTERY CONNECTION (electric-start type)

In the case that the specifications of the battery are 12V and more than 18A.h, connect its positive lead to the electromagnetic coil while connect its negative lead to engine mount strew, base screw any place capable of grounding with the engine well.

Make sure the battery leads are connected tightly and no corrosion is found. If any, eliminate it.

⚠ WARNING

- **The battery may give or off explosive gas, keep sparks, flames and cigarettes away. Charge or use it I an area with gook ventilation.**
- **The battery contains sulphonic acid (electrolyte). Con tact with skin or eyes may causr severe burns. Wear protective clothing and a face shield.
If electrolyte gets in your skin, flush with water; if gets in your eyes, flush with water for at least 15 minutes and call a physician at once.**
- **Electrolyte is poisonous. If swallowed, drink large quantities of water or milk, and follow with milk of magnesia or vegetable oil and call a physician.**
- **Keep out of reach of children.**

CAUTION

- **Do not add tap water to the battery instead of distilled water, or the battery life will be shortened.**

- Do not add distilled water over electrolyte upper level mark, or electrolyte will spill out to corrupt the engine parts. If so, be sure to wash them away with water.
- Make sure not to connect the battery leads in reverse order, or short-circuit or breaker's cutting may result.

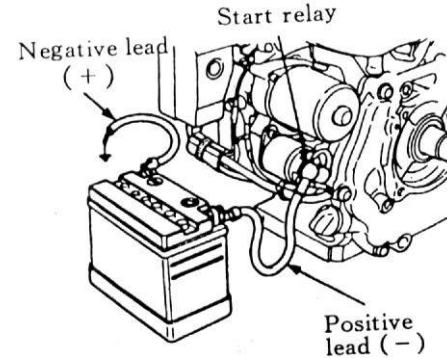

CONTROL CONNECTION OF REMOTE DISTANCE (OPTION)

The holes in levers of both the choke and throttle valve are used for mounting optioned steel wires. Fig.2, 3 & 4 shown illustrate how to mount a solid steel wire and a meshed steel wire. If choosing a meshed steel wire, a return spring is added.

If necessary, you may unscrew the damping nut on the throttle valve lever slightly when controlling the throttle valve by a remote-controlled steel wire.

Accessory Options:

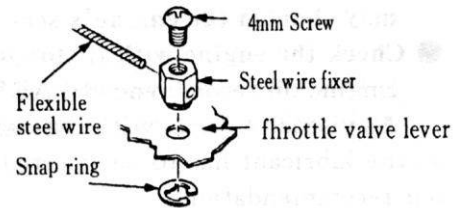
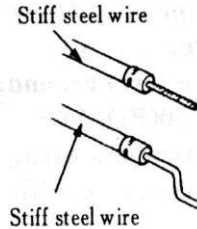

Fig. 2

Remote - Controlled Throttle:

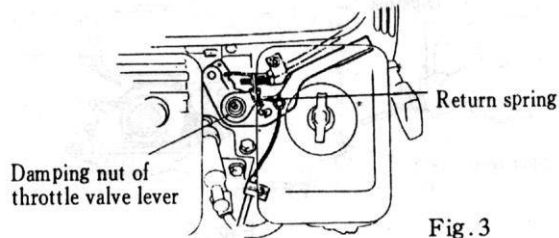

Fig. 3

Remote - Controlled Choke:

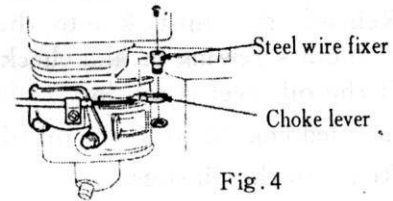

Fig. 4

PRE-OPERATE INSPECTION

I .ENGINE OIL

CAUTION

- Engine oil is a key factor in deciding the engine's performance. Do not apply engine oil with additives or 2-stroke gasoline oil, as they haven't enough lubrication, which may shorten the engine's service life.
- Check the engine with it stopped on a level ground.

Engine oil recommended: SAE10W-30 (Fig.5)

As viscosity varies with regions and temperatures, so the lubricant has to be selected in a accordance with our recommendation.

Check (Fig.6)

1. Ensure that the engine is stopped on a level ground.
2. Remove the dipstick and clean it.
3. Reinsert the dipstick into the oil filler without screwing in, and check oil level.
4. If the oil level is too low, add recommended engine oil to the filler neck.
5. Reinstall the dipstick.

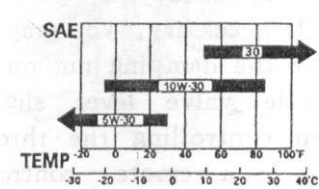

Fig. 5

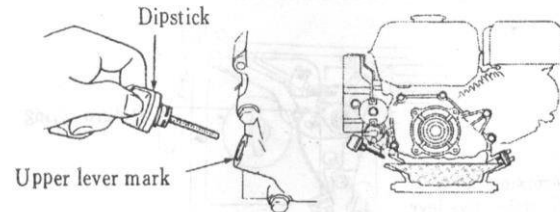

Fig. 6

CAUTION

- **Run with insufficient engine oil may damage the engine severely.**

II. OIL IN THE REDUCTION GEAR BOX (only for the model equipped with it)

1/2 Reduction gear box with an auto-centrifugal clutch.

Brand of the oil is the same as that of engine oil.

Oil capacity: 0.50 liters

Check the oil level in the following order (Fig. 7)

1. Remove the dipstick and clean it.
2. Reinsert the dipstick without screwing it in, and then take out it and check oil level.
3. If the oil level is too low, and recommended engine oil until it arrives the upper level mark.
4. Reinstall the dipstick.

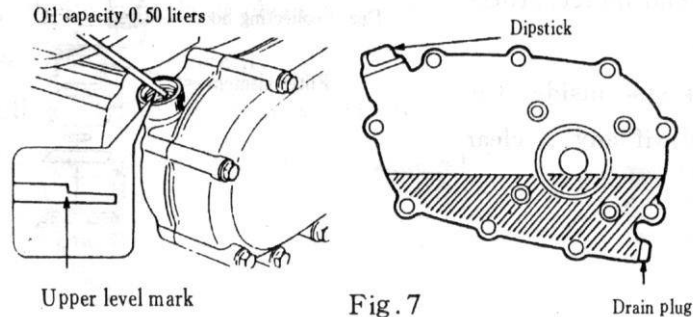

III. AIR CLENERER

1. Double-core type (Fig. 8)

Dismantle the air cleaner housing and check its filter element, make sure it is clean and intact, otherwise clean or replace it.

2. Dust – collecting type (Fig. 9)

- a) Dismantle the dust – collecting hood and check the core of the air cleaner, make sure it is clean and intact, otherwise clean or replace it.
- b) Check if dust exists inside the dust – collecting hood, if any, clear away.

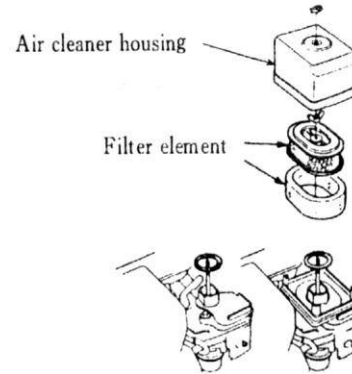

Fig. 8

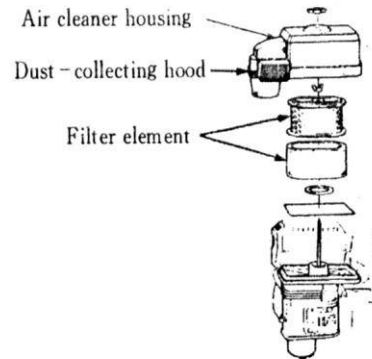

Fig. 9

3. Semi –dry type (Fig. 10)

- a) Remove the air cleaner housing and check the filter element for dirt and impurity. Clean or replacement should be done if necessary.
- b) Check the air cleaner for dirt, and remove it if any.

4. Oil – bath type (Fig. 11)

- a) Dismantle the air cleaner housing and check its core, make sure it is clean and intact, otherwise clean or replace it.
- b) Check oil level and oil quality. If the oil level is too low, add recommended engine oil to oil level mark.

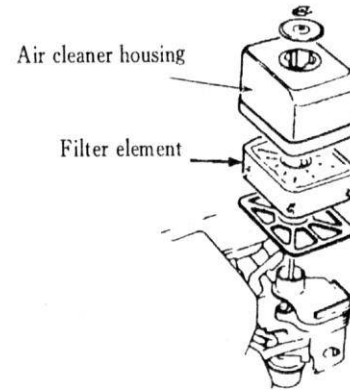

Fig. 10

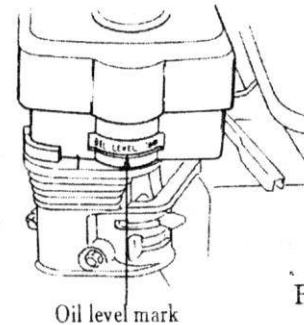

Fig. 11

CAUTION

- **Never run the engine without an air cleaner, or sever wear of the engine may occur.**

IV. FUEL AND FUEL TANK

1. Fuel

The engine must apply unleaded gasoline with an octane number over 86. Using unleaded gasoline will decrease the possibility of producing carbon deposit and prolong the engine's service life.

Never apply used or polluted gasoline or a mixture of gasoline and engine oil. Make sure the fuel is free of dirt and water.

2. Gasoline Containing Alcohol

If you decide to use a gasoline containing alcohol (fuel blend), be sure its octane rating it at least as high as that recommended by the company. There are two types of "gasohol". One contains ethanol, and the other contains methanol. Neither gasoline containing more than 10% ethanol nor 5% methanol is allowed to be used. If methanol content in the fuel blend exceeds 5%, it may bring bad effect on the engine performance, besides, it may damage metals, rubber and plastic parts.

CAUTION

- **Handle fuel with care because it can damage plastic and painted surfaces.**
- **It is normal when you hear occasionally light spark knock or pinking with the engine running under heavy load.**
- **Should spark knock or pinking be heard at a speed under normal load, change brand of gasoline; if such phenomenon still happens, consult your dealer for help, otherwise, the**

engine may be damaged.

3. Fuel Tank

Fuel tank capacity: 2.5liters for 160F, and3.6liters for 168F & 168F – 2.

4. Check

- a) Remove the fuel filler cap and check fuel level.
- b) If the fuel level is too low, refuel the tank. Remember adding fuel not over the fuel filter shoulder (Fig. 12).

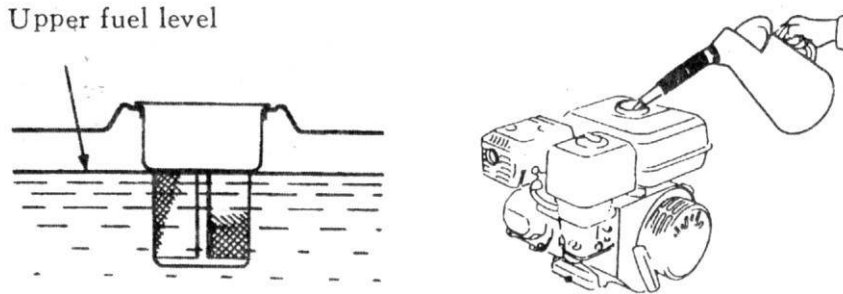

Fig. 12

⚠ WARNING

- **Gasoline is extremely flammable and is explosive under certain conditions. Refueling in a well – ventilator area with the engine stopped. Do not smoke and allow flames or sparks in the area where gasoline is stored or where the fuel tank is refueled.**
- **Do not overfill the tank (there should be no fuel in the filler neck). After refueling, make sure the fuel tank cap is set back securely.**
- **Be careful not to spill fuel when refueling. Spilled fuel or fuel vapor may ignite. If any fuel is spilled, make sure the area is dry enough before starting the engine.**
- **Avoid repeated or prolonged contact with skin or breathing of fuel vapor.**
- **Keep out of reach of children.**

STARTING OF THE ENGINE

1. Push the fuel cock to “ON”. (Fig. 13)

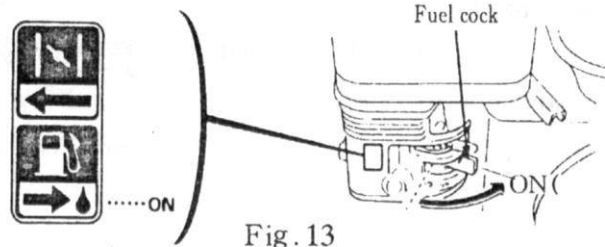

2. Push the choke lever to “CLOSE”. (Fig. 14)

NOTE

If the engine is hot, closing the choke is unnecessary.

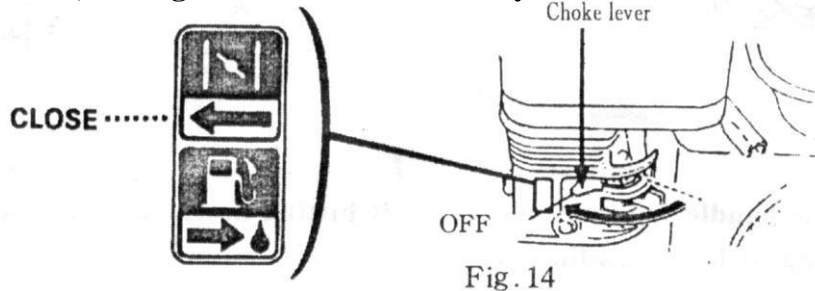

3. Move left the throttle lever a little (Fig. 15)
4. Start the engine (Fig. 16).
 - a) Push the engine switch to “ON”.
 - b) Pull slightly the starting rope handle up until feeling anti-action, and then make a rapid pull.

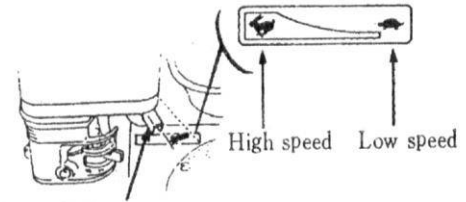

Throttle valve lever

Fig. 15

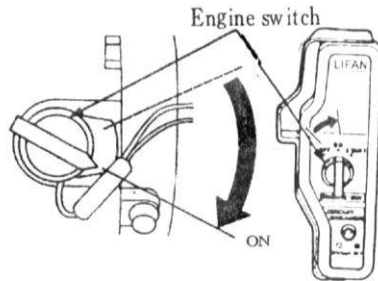

(Electric start type)

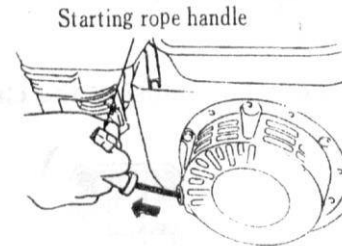

Starting rope handle

Fig. 16

CAUTION

Releasing the handle suddenly may make it hitting the engine. Release the handle slowly conforming with its recoiling force.

c) Electric starter

Push the engine switch to “START” and remain there the engine starts. Once the

engine starts, reset the engine switch to “ON”.

CAUTION

Use the engine switch not more than 5 minutes each time to avoid damage of the engine. Try once more 10 minutes later after last attempt failures.



Engine switch
(Electric start type)

OPERATION

1. Preheat the engine and push back the choke lever to “OPEN”(Fig. 17).

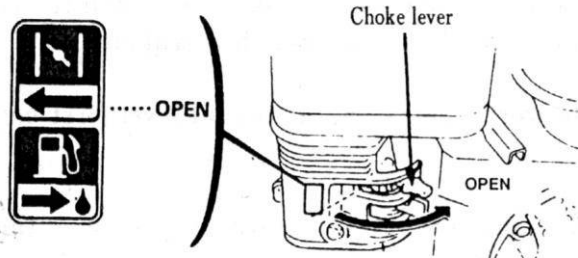

Fig. 17

2. Set the throttle lever in proper position to ensure the engine runs at required velocity. (Fig.18)

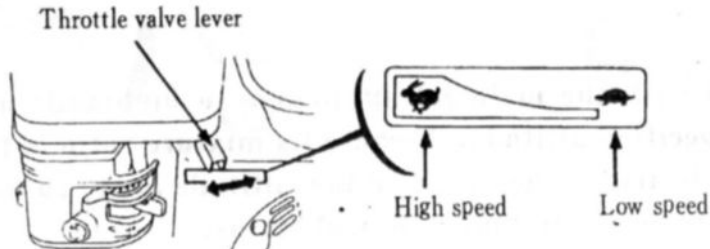

Fig. 18

★ Engine Oil Alarm

The engine oil alarm is designed to alarm the user the fact that the engine oil in the crankcase is insufficient. Run with insufficient engine oil may damage the engine. Once oil level in the crankcase is too low, the engine oil alarm will stall the engine automatically to make it free of damage while the engine switch is still at “ON”.

CAUTION

If the engine still fails to work, check the engine oil level first before go to other check items.

★ Operating on Highlands

On highlands, the standard mixture ratio is relatively too big so the engine performance may be impaired while the fuel consumption may increase. This problem can be solved as follows: replace the main jet of carburetor with a smaller one, then, adjust the idly screw. If always using on highlands with a height above sea level of 1830 meters, ask your dealer for doing the job.

The engine power will decrease by about 3.5% with every 305 meters up in height, even the proper main jet is used.

CAUTION

The engine equipped with the main jet applicable to highlands may be damaged seriously in area below specified altitude, because its mixture ratio is too thin, output drops and the engine overheats for operation in low altitude area. In the case, ask your dealer to recover the engine to its normal technical status.

STOP

In an emergency, push the engine switch to “OFF” to stall the engine. Stop it in normal in the following sequence:

1. Push right the throttle valve lever to the bottom (Fig. 19).
2. Push the engine switch to “OFF” (Fig. 20).
3. Set the fuel switch to “OFF” (Fig. 21).

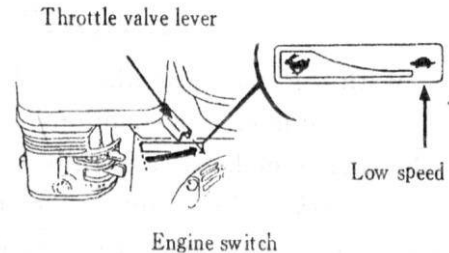

Fig. 19

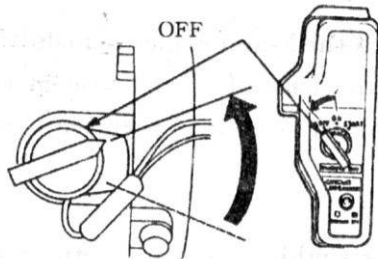

Fig. 20

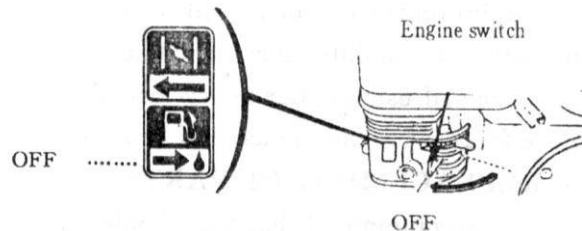

Fig. 21

EXHAUST CONTROL SYSTEM

With the engine running, carbon monoxide, oxide of nitrogen and hydrocarbon will produce, and in certain conditions, oxide of nitrogen and hydrocarbon will react chemically each other to make smoke while carbon monoxide is toxic, so exhaust control of them is very important. The company decreases the exhaust emissions by introducing poor-fuel carburetors and other devices into the engine to solve the problem.

To keep the exhaust of your engine within the standard exhaust emission values, pay attention to the following:

I . MAINTENANCE

Maintain the engine periodically in accordance with the Maintenance Schedule in the manual. The maintenance schedule is made out on the base of normal use in normal conditions, if using under heavy load, dusty or wet circumstances or in high temperature, more frequent maintenance will be necessary.

II . REPLACEMENT OF PARTS

We recommend that you should choose such parts which are manufactured by our Co. or equivalent to these in quality as replacement ones. Replacement without so high quality may impair the exhaust control system in effectiveness.

III. MODIFYING

Modifying the exhaust control system may make actual exhaust emissions exceeding statutory limit values. Illegal modification is as follows:

1. Dismantle or modify any part of air inlet or outlet system.
2. Modify or take off speed-adjusting connection device or speed adjustment device to result in the engine's running or outside the set parameters.

IV. PROBLEMS AFFECTING EXHAUST EMISSIONS

1. Difficult starting or difficult stopping.
2. Unstable idling.
3. Give off black smoke or consume too much fuel.
4. Poor ignition sparks or sparks returned.
5. Ignition is too advanced.

Once you find any of above problems, contact your dealer for help.

MAINTENANCE

I . MAINTENANCE SCHEDULE

To keep the engine in a sound condition, the user should maintain it according to the table below:

Frequency	Items	Each time	Initial 1 month or 20 Hrs	Initial 3 month or 50 Hrs	Every 6 month or 100 Hrs	Every 1 years or 300 Hrs
Engine oil	Check oil level	△				
	Replace		△		△	
Reduction gear oil	Oil level check	△				
	Replace		△		△	
Air cleaner	Check	△				
	Clean			△cc	△①★	
	Replace-clean					△★★
Deposit cup	Clean				△	
Spark plug	Clean, adjust				△	
	Replace					△
Spark eliminator	clean				△	
Idling	Check-adjust					△②
Valve clearance	Check-adjust					△②
Fuel tank & Fuel filter	Clean					△②
Fuel supply line	Check	Every two years (do a replacement if necessary)				

CAUTION

Use only parts manufactured by the company or equivalents in quality; otherwise damage to engine may occur.

NOTES

***: Only for inside-ventilating double-core carburetors.**

**** : Only for paper core air cleaners.**

- ① More often than that in the schedule if in dusty circumstances.
- ② The items should be done by your dealer you are specially trained and is well equipped with tools.

⚠ WARNING

Stall the engine before service. If service is required with the engine running, be sure to keep good ventilation in the area. The exhaust emissions from the engine contain toxic carbon monoxide, inhaling of it may do harm to personnel and even result in death of personnel.

II. METHOD

1. Replacement of Engine Oil

A still hot engine is helpful to drain out the engine oil in the crankcase rapidly and entirely.

- a) Turn off the oil filler cap and drain plug to drain engine oil thoroughly. Reinstall the drain plug and screw in securely (Fig. 22).
- b) Fill the specified engine oil to the upper level mark.
- c) Reinstall the oil filler cap.

Engine oil capacity of the 1/2 reduction gear box is 0.5 liters; engine oil capacity of the crankcase is 0.6 liters.

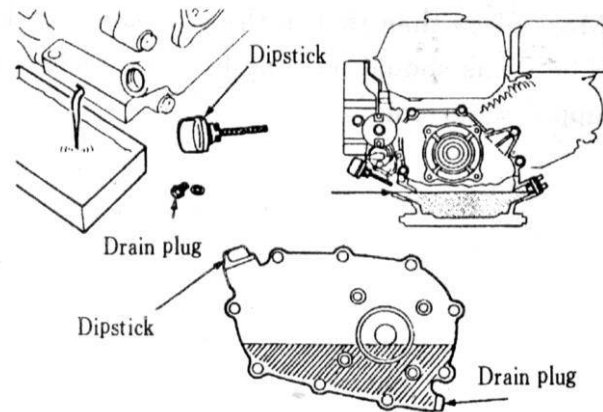

Fig. 22

NOTE

Do not dump oil containers or discarded engine oil into rubbish boxes or onto the ground. For the sake of environmental protection, we suggest you take in discarded engine oil with a closed container and bring to local recycling station.

2. Service of Air Cleaner

A dirty air cleaner may block enough air's flowing into the carburetor. To keep the carburetor in good working conditions, please service the air cleaner periodically. If operating the engine in extremely dusty area, the job should be done more often.

⚠ WARNING

Never clean the air cleaner core in gasoline or low flash-point detergents, or explosion may happen.

CAUTION

Never run the engine without an air cleaner, or air with dirt and dust may enter the engine so speed the engine's wear.

★ Double-core type (Fig. 23)

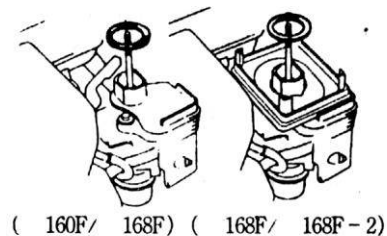
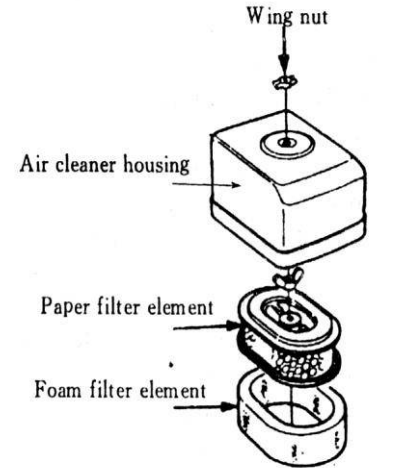

Fig. 23

Unscrew the wing nut, dismantle the air cleaner housing. Check the two cores for damage. If any, replace with new one.

- a) Foam filter element: clean with home detergents and warm water (or non-flammable or high flash – point cleaning solvents) and dry up, then soak in clean engine oil until saturated. Squeeze out excess oil, otherwise, the engine will discharge smoke in starting stage.
- b) Paper filter element: knock the core against a solid plane to get rid of accumulated dust or blow out dust from inside to outside with high – pressure air flow (not more than 30psi). Never clean with a brush, as brushing may force the dust into the core fiber. If the core is extremely filthy, replace it with a new one.

★**Dust – collecting type (Fig. 24)**

- a) Unscrew the wing nut, dismantle the air cleaner housing, check the two cores for damage. If any, replace damaged core with new one.

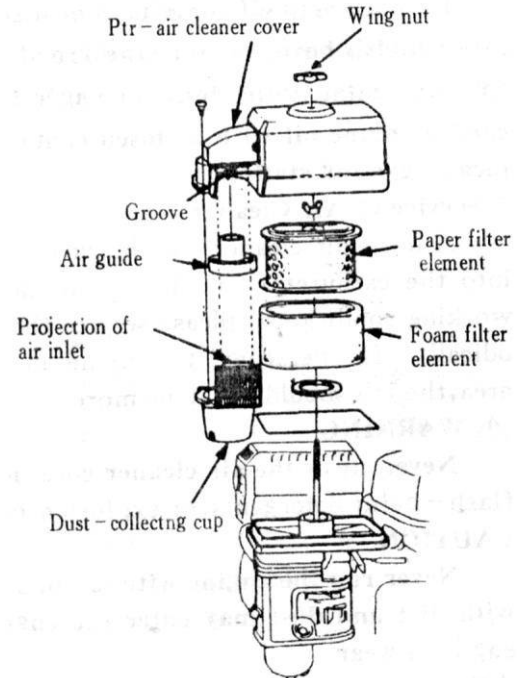

Fig. 24

- b) Foan filter element: clean with home detergents and warm water (or non – flammable or high flash – pointcleansing solvents) and dry up, then soak in clean engine oil until saturated. Squeeze out excess oil, otherwise, the engine will discharge smoke in starting stage.
- c) Paper filter element: knock the core against a soild plane to get rid of accumulated dust or bl-
ow out dust from inside to outside with high – pressure air flow (not more than 30 psi). Never clean with a brush, as brushing may force the dust into the core fiber. If the core is extremely filthy, replace it with a new one.
- d) Clean the dust – collecting cup: turn off the three special semi – round screws and remove the cup, wash parts with water and then dry up. Install it to original position.

CATION

● **The dust – collecting core should be so installed to made sure that the projection of sir inlet just fits into the groove in the pre-air cleaner cover.**

● **Install the air guide in correct order.**

★ **Semi-dry type (Fig. 25)**

- a) Unscrew the wing nut, remove the air cleaner housing, then take out the filter element.
- b) Clean the filter element with non-flammable or high flash-point cleansing solvents, and dry it up.
- c) Soak the core in clean engine oil until saturated. Squeeze excess oil, otherwise the engine will discharge smoke in starting stage.
- d) Install the parts to original position.

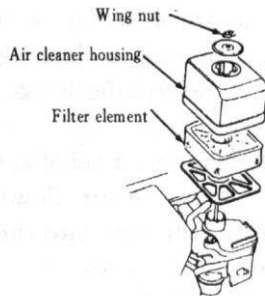

Fig. 25

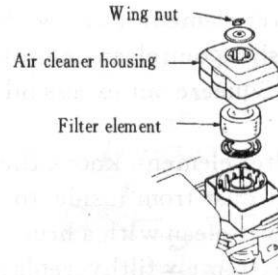

Fig. 26

★ Oil bath type (Fig. 26)

- a) Remove the wing nut and air cleaner housing, and take out the filter element. Check if both the cores are damaged. If any, replace it with new one.
- b) Clean the bores with home detergents (or high flash-point cleansing solvents) and warm water, and dry them up.
- c) Soak them in clean engine oil until saturated. Squeeze excess oil, or the engine will discharge smoke in starting stage.
- d) Empty the air cleaner housing of oil, clear away the dust inside with non-flammable or high flash-point cleansing solvents, and dry it up.
- e) Fill the air cleaner housing with the specified engine oil to the standard oil level mark.
- f) Fit the parts to original position.

3. Washing of Deposit Cup (Fig. 27)

Set the fuel switch at “OFF”, remove the deposit cup and O-ring. Wash them in non-flammable or high flash-point cleansing solvents, and then dry them up, at last, carry out reinstallation. Set the fuel switch to “ON” and check for leaks.

⚠ WARNING

- Gasoline is extremely flammable and explosive in certain conditions. Keep cigarette, sparks and open flames away.
- After reinstalling the deposit cup, check it for leakage and make sure the area around the engine is dry enough.

4. Spark Plug (Fig. 28)

Spark plug type: F6TC

Proper spark plug clearance ensures the engine’s normal running under no deposit around the spark plug.

- a) Remove the spark plug by means of spark plug wrench.

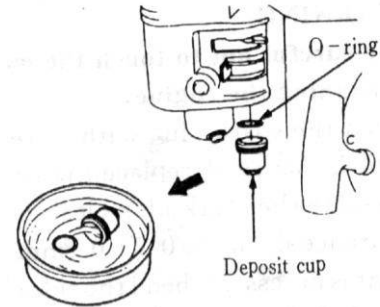

Fig. 27

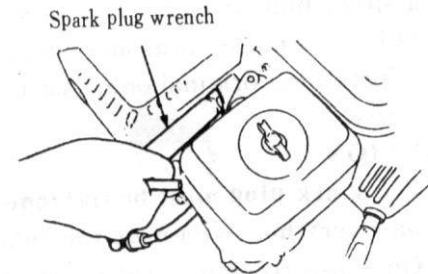

Fig. 28

⚠ WARNING

Be careful not to touch the muffler during or just after the engine.

- b) Clean the spark plug with a steel brush. If the insulator is damaged, replace the spark plug instead.
- c) Measure the spark plug clearance with a feeler. The clearance should be $0.7\sim 0.8\text{mm}$ (Fig. 29). If adjustment is necessary, bend the side electrode carefully.
- d) Check if the spark plug gasket is in good conditions, or replace with a new one. Screw on the spark plug to the bottom first by hand and then tighten it up by a spark plug wrench. If a new spark plug is used, twist $1/2$ more turns after impacting the gasket; if reinstall the original one, just twist $1/8\sim 1/4$ more turns.

CAUTION

- **The spark plug must be tightened securely, or it may become very hot to damage the engine.**
- **Only use recommended spark plug or the equivalent. Incorrect heat range of the spark plug may damage the engine.**

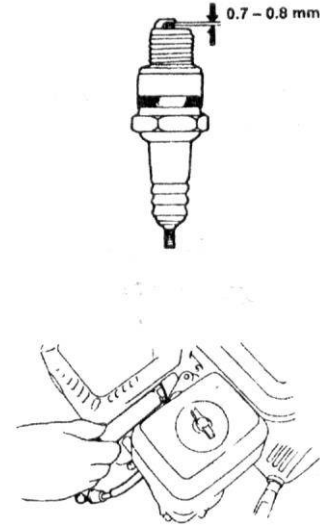

Fig. 29

5. Spark Eliminator (Option)

The spark eliminator should be serviced at least once every 100 hour's operation so as to keep it in a sound condition.

⚠ WARNING

The muffler is very hot during running the engine and even a long time after stopping. Never touch it, or you may get burns. Service after the engine cools down.

- a) Unscrew two nuts M4, and remove the exhaust elbow from the engine body (Fig.30).
- b) Turn off five screws M5 from the muffler guard and take out the latter.
- c) Turn off screw M4 from the spark eliminator and separate it from the muffler.
- d) Clear away carbon deposit from the spark eliminator mesh with a brush.
- e) Reinstall the spark eliminator in reverse order of removal.

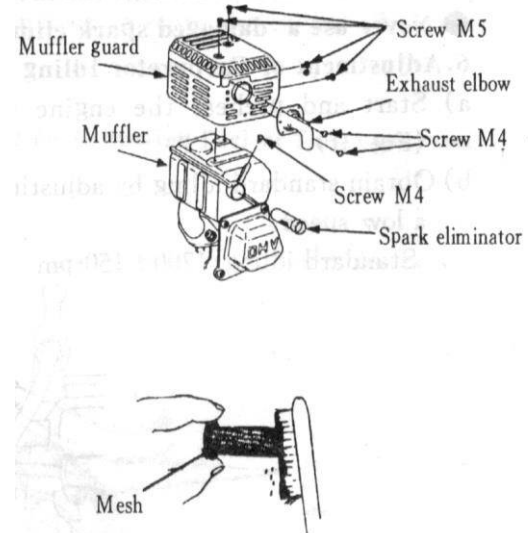

Fig. 30

CAUTION

- Be careful not to damage the mesh of the spark eliminator.
- Never use a damaged spark eliminator.

6. Adjustment of Carburetor Idling

- Start and preheat the engine until arriving at its normal working temperature (Fig.31).
- Obtain standard idling by adjusting the throttle fixing screw under the engine runs at a low speed.

Standard idling: 1700 ± 150 rpm

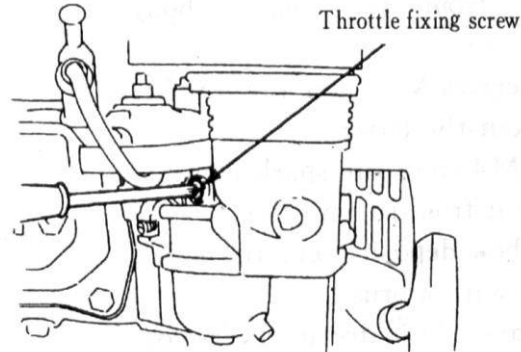

Fig. 31

TRANSPORT, STORAGE AND REMOVAL FROM STORAGE

I . TRANSPORT

Transport with the fuel switch turned off. Transport or store the engine it is cool so as to avoid getting burns or fire.

CARTION

Do not incline the engine so as to avoid spilling fuel. Spilled fuel or fuel vapor may ignite to cause fire.

II . STORAGE

If the engine is not kept in use for a long time, be sure to store it properly. Make sure the storage area is dry and free of dust.

1. Replace engine oil (Fig.32).

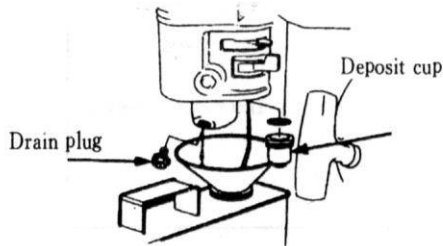
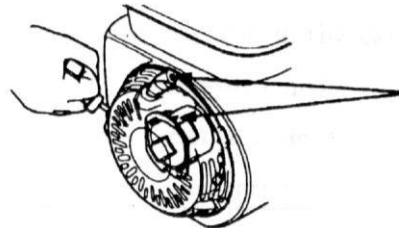

Fig. 32



Align the arrow of the starting sleeve with the hole in the starter

Fig. 33

2. Disconnect the spark plug. Fill a spoon of fresh engine oil from the spark plug mount hole into the cylinder. Rotate the engine to distribute engine oil evenly, followed by fitting the spark plug to original position.
3. Pull the starting rope slowly until feel a slight anti-action, and then keep pulling so as to align the arrow of the starting sleeve with the hole of the starter. At this time, both the inlet and outlet valves are closed so to help prevent the engine inside from rusting (Fig. 33).
4. Cover the engine so keep dust away.
5. Electric starter: disconnect the battery and store in dry and cool area. Charge once every month.

III. REMOVAL FROM STORAGE

Before reusing, service the engine in accordance with the instructions of the table.

Storage time	Service item
Within one month	
One~two months	Drain out original fuel of the fuel tank and refuel
Two months~one year	Drain out original fuel of the fuel tank and refuel; Drain out fuel in the carburetor①; Empty the deposit cup②.
Above one year	Drain out original fuel of the fuel tank and refuel; Empty the fuel cup in the carburetor①; Empty the deposit cup②; Move the engine from the storage place, fill it with fuel, then start up it.

① Screw off the drain plug and drain out fuel in the carburetor.
② Turn off the engine switch first, disconnect the deposit cup and empty it.
Note: For the sake of environmental protection, we recommend to fill the discarded fuel into a closed container and bring to local recycling station.
Never pour freely.

⚠ WARNING

Fuel is extremely flammable and explosive under certain conditions. Keep cigarette, open flames and sparks away from operating site.

TROUBLESHOOTING

I . STARTING ENGINE DIFFICULTLY

TROUBLE	CAUSE	REMEDY
1. Something wrong with the fuel system	There is no enough fuel in fuel tank or fuel cock is closed	Fill fuel, open fuel cock
2. Fuel supply is blocked or on fuel.	Air vent in the filler cap is clogged.	Dredge air vent
	Fuel cock is clogged.	Clean first and then dredge
▲ Normal cylinder compression	Improper or clogged main jet	Readjust or clean, blow to get through
▲ Normal spark	Needle valve is closed improperly or start hole is clogged	Dismantle needle valve and repair, clean, blow to get through
	Floater is damaged or sticking	Repair floater

TROUBLE	CAUSE	REMEDY
1. something wrong with the fuel system ▲ Normal cylinder compression ▲ Normal spared ▲ Fuel flows easily and smoothly	Fuel is filthy or deteriorated	Replace
	There is filthy or deteriorated	Replace
	Too much fuel in engine cylinder	Drain extra fuel, dry up spark plug electrodes
	Wrong fuel brand	Select proper fuel brand corresponding with requirements
1. Spark plug is in bad condition ▲ Normal cylinder compression ▲ Normal fuel supply ▲ Normal high-pressure coil spark	Too much carbon fouling and dirt around electrodes	Clear away
	Electrodes are burn damaged seriously or insulators damaged	Replace spark plug
	Improper electrodes gap	Adjust to proper value
1. No high-pressure coil spark ▲ Normal cylinder compression ▲ Normal fuel supply ▲ Normal spark plug	High-pressure coil is damaged	Replace
	Ignition coil damaged	Replace
	Magneto loses magnetism	Replace

TROUBLE	CAUSE	REMEDY
1. Poor cylinder compression ▲ Normal fuel supply system ▲ Normal ignition system	Piston ring is so worn to over its wear limit	Replace a set of piston rings
	Piston ring is sticking	Clear up carbon fouling
	Piston ring is broken	Replace
	Spark plug is not installed tighten or without a gasket	Tighten with a gasket in
	Air leakage between cylinder block and cylinder	Check cylinder gasket and the flatness of the surface by which cylinder block on-tacting with cylinder head; tighten cylinder bolts in the order to stipulated torque
	Air leakage in valve	Check valve clearance and tightness, repair if necessary

⚠ WARNING

- When testing the spark plug, never hold the high- voltage wire of the spark plug with wet hand.
- Make sure there is no spilled fuel outside the engine and that the spark plug isn't dipped with

fuel.

- **To prevent fire, keep sparks far away from the spark plug mount hole.**

Once you find any of above problems, contact the authorization entitle to the dealer of the privilege helps for you.

II. LOW GASOLINE ENGINE POWER OUTPUT

TROUBLE	CAUSE		REMEDY
When turning throttle greater, speed increase responds slowly or speed is decreased even engine stops	Ignition	Incorrect ignition time	Readjust ignition advance angle
	Fuel supply system	Air in fuel line of fuel line clogged.	Exhaust air or dredge fuel line
		Main jet is not adjusted properly.	Readjust
		In carburetor, needle valve hole and main jet clogged	Clean and blow to get through
		Fuel cock is clogged up	Clean, replace damage part.
		Too much carbon fouling in combusting chamber	Clear away
		Air cleaner is clogged up.	Clean filter element

TROUBLE	CAUSE		REMEDY
Do.	Do.	Intake pipe is leaking	Replace or replace it
	Poor compression	Piston or cylinder or piston ring is worn.	Replace it with a new one
		Air leakage from the surface by which cylinder block contacting with cylinder head.	Replace cylinder gasket
		Too big or too small valve clearance.	Adjust it
		Valve tightness is poor	Repair

III. GASOLINE ENGINE ACNNOT RUN SMOOTHLY

TROUBLE	CAUSE	REMEDY
Engine is pinking	Piston, cylinder or piston ring is worn excessively.	Replace the worn
	Piston pin and piston pin hole are worn excessively.	Replace piston or piston pin
	Tie rod small head is worn excessively.	Replace tie rod
Do.	Roller bearing for crankshaft main shaft is worn	Replace roller bearing

TROUBLE	CAUSE	REMEDY
Abnormal combustion	Engine is too hot	Shoot trouble
	Too much carbon fouling in combustion chamber	Clear away
	Improper gasoline brand or low gasoline quality	Replace with qualified gasoline
Engine cannot start because of spark lacking	There is water in floater room	Clean
	Improper spark plug electrodes clearance	Adjust
	Incorrect ignition time	Readjust
	Something wrong with induced coil, and so on	Check and replace damaged parts

IV. STOP SUDDENLY WHEN RUNNING

TROUBLE	CAUSE		REMEDY
Stop suddenly	Fuel supply system	Fuel is used up	Fill fuel
When running	Do.	Carburetor is clogged	Check fuel line and dredge
		Floater is leaking	Repair
		Needle valve sticks	Dismantle floater chamber And eliminate it

TROUBLE	CAUSE		REMEDY
When running	Ignition system	Spark plug is struck through, or short-circuited by carbon deposit	Replace spark plug
		Side electrode of spark plug is dropped out	Replace spark plug and remove the dropped object
		Hi-voltage wire is dripped out	Connect it
		Engine oil in the crankcase is insufficient	Add engine oil until it arrives the upper level
Do.	Do.	Ignition coil is struck through to be short-circuited	Replace ignition coil with new one
		Parking wire is located on the engine body	Find out meeting and insulate
	The other	Cylinder is pulled considerably, valve falls off	Repair or replace damaged parts

V. GASOLINE ENGINE IS EXCESSIVELY HOT

TROUBLE	CAUSE	REMEDY
Gasoline engine is excessively	Improper ignition time	Adjust ignition advance angle properly
	Insufficient engine oil supply	Refill sufficient engine oil
	Exhaust pipe is clogged	Dredge exhaust pipe
Do.	Flow guard is leaking	Repair leakages
	Dirt or something like the fill up among air cooling fins	Clear away dirt or something like this
	Cooling fan is loosen, losing function	Reinstall it well
	Cylinder, piston or piston ring is worn, Resulting in air flow between cylinder and crankcase	Replace tie rod
	Tie rod deformation makes piston and Cylinder bushing side wear.	Replace tie worn part
	Improper adjustment of engine speed produces excessive rotational speed	Readjust engine speed to proper value by speed regulator
	Bearing of crankshaft is burn out	Replace main bearing

NOTE: The gasoline engine should run under certain temperature. Generally, permitting temperature at the flow guard outlet is between 80~100°C, while the temperature of the crankcase is about 60°C under the magneto. If temperatures surpass the limits, it is an indication that gasoline engine is excessive hot.

VI. THERE IS ABNORMAL NOISE WHEN ENGINE RUNNING

TROUBLE	CAUSE	REMEDY
There is noise of beating or piston slap is heard	Piston or piston ring or cylinder is worn	Replace the worn
	Tie rod or piston pin and piston pin hole is worn	Replace the worn
	Main bearing of crankshaft is worn	Replace
	Piston ring is broken	Replace
There is metal-beaten noise in abnormal combustion	Too much carbon deposit in combusting chamber	Clear away carbon deposit
	Too small electrodes clearance of spark plug	Adjust electrodes clearance properly
	Engine is flooded with fuel	Check relative parts such as carburetor
	Improper fuel brand	Replace fuel
	Engine is excessively hot	Shoot trouble

TROUBLE	CAUSE	REMEDY
The other	Improper valve clearance	Readjust valve clearance properly
	Fly wheel is not connected to crankshaft tightly	Connect tightly

SPECIFICATIONS

I . MAIN SPECIFICATIONS

1. Design Data

Model Items	160F	168F/168FD	168F-2/168F-2D
L × W × H (mm)	317×341×318	305×365×335 〈305×385×334〉	313×376×335 〈313×396×335〉
Dry weight (kg)	13	14 〈16〉	16 〈17.9〉
Engine type	4-stroke, OHV, single cylinder tilt 25°		
Displacement (cm ³)	118	163	196
Bore × stroke (mm)	60×42	68×45	68×54
Max. power in theory (kW/r/min)	2.9(4PS)/3600	4.1(5.5PS)/3600	4.8(6.5PS)/3600
Power recommended (kW/r/min)	2.2(3PS)/3600	3.4(4.6PS)/3600	4(5.5PS)/3600
Max. torque (N· m /r/min)	6.7/2500	9.0/2500	11.0/2500
Fuel consume. (g/kWh)	394		
Cooling system	Force air - cooled		

el Items	Mod	160F	168F/168FD	168F-2/168F-2D
Ignition system		Non – transistorized ignition (TCI)		
Spark plug type		F6TC		
Out direction of power shaft		Counterclockwise		

2. Date relating to Adjustment

Item	Date
Spark plug clearance	0.7~0.8mm
Carburetor idling	1700±150rpm
Valve clearance (cold engine)	Intake: 0.15±0.02mm; Exhaust: 0.20±0.02mm

NOTES

- Technical data vary with type of engine, therefore, they are subject to change without notice.
- Data in < > are suitable for engine which is equipped with reducer.

II. TIMING OF DISTRIBUTION

Intake valve opening: BTDC10°;

Intake valve closing: ABDC20°;

Exhaust valve opening: BBDC30°;

Exhaust valve closing: ATDC10°

III. TIGHTENING TORQUE OF IMPORTANT BOLTS

S/N	Item	Torque Value (N · m)
1	Cylinder head bolt	24
2	Flywheel bolt	70~80
3	Crankcase cover bolt	24
4	Tie – rod bolt	12

ELECTRIC DIAGRAM

Bl	Black
Y	Yellow
G	Green

